

# GT SERIES GAS TEST GAUGE

Utility gas test gauge with horizontal, vertical or bell shaped housing  
For pressure tests of residential and commercial piping systems

## SPECIFICATIONS

<b>Dial</b>	2" (50 mm)
<b>Case</b>	Black painted steel, dry non-fillable
<b>Wetted Parts</b>	Copper alloy Bourdon tube & socket Steel block (Horizontal/vertical chrome plated steel)
<b>Ranges</b>	Standard ranges: 0/15 psi to 0/200 psi
<b>Bezel</b>	Steel, press on
<b>Lens</b>	Plastic
<b>Pointer</b>	Black aluminum
<b>Connection</b>	Lower mount 1/2", 3/4" or 1" FNPT
<b>Scale</b>	Standard: single scale psi
<b>Accuracy</b>	3-2-3% of span, ASME B40.1 Grade B
<b>Ambient Temp</b>	-40° F to 160° F
<b>Test Block</b>	Steel with valve for pressurization

*Design meets or exceeds ASME B40.100 pressure gauge standard.*



## AVAILABLE OPTIONS\*

- Custom Dial
- Special Connection Size
- Other Ranges

## PART NUMBERING SYSTEM

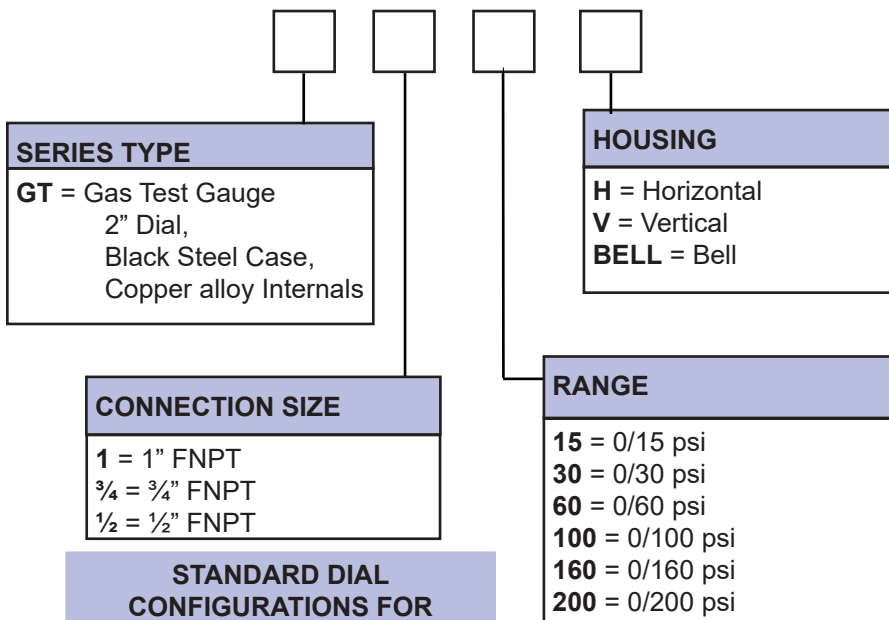

\*Lead times/minimums may apply

## APPROXIMATE SHIPPING WEIGHTS/ BOX QUANTITIES

### HORIZONTAL 2" DIAL SIZE

1/2" FNPT: 0.65 lbs (0.28 kg)/50 pcs  
3/4" FNPT: 0.65 lbs (0.30 kg)/50 pcs  
1" FNPT: 0.85 lbs (0.38 kg)/50 pcs

### VERTICAL 2" DIAL SIZE

1/2" FNPT: 0.70 lbs (0.32 kg)/50 pcs  
3/4" FNPT: 0.65 lbs (0.28 kg)/50 pcs  
1" FNPT: 0.85 lbs (0.38 kg)/50 pcs

### BELL 2" DIAL SIZE

1/2" FNPT: 0.40 lbs (0.20 kg)/50 pcs  
3/4" FNPT: 0.50 lbs (0.22 kg)/50 pcs  
1" FNPT: 0.60 lbs (0.26 kg)/50 pcs

## STANDARD DIAL CONFIGURATIONS FOR GAS TEST SERIES

Dial Range	Figure Intervals	Graduation Intervals
0/15 psi	1 psi	0.1 psi
0/30 psi	5 psi	0.25 psi
0/60 psi	10 psi	0.5 psi
0/100 psi	20 psi	1 psi
0/160 psi	20 psi	2 psi
0/200 psi	20 psi	5 psi

NOTE: Not all part numbers or options are available from stock. Consult PIC Gauges for availability.