



# RECTANGLE (EDGE) GAUGE

**Compact rectangle/edge gauge, plastic case, copper alloy wetted parts**  
**Suitable for air, water, oil, gas or other media not corrosive to copper alloy**

## SPECIFICATIONS

<b>Dial</b>	1 3/4" x 1/2" horizontal or vertical
<b>Case</b>	Plastic, with or without mounting bracket
<b>Wetted Parts</b>	Copper alloy
<b>Ranges</b>	0/60 psi, 0/100 psi, 0/120 psi
<b>Lens</b>	Plastic
<b>Pointer</b>	Red plastic
<b>Connection</b>	Back mount 10/32" female thread or 1/32" hose barb connection
<b>Scale</b>	Standard: psi/kg/cm <sup>2</sup>
<b>Accuracy</b>	5% of span on ASME B40.1 Grade D
<b>Ambient Temp</b>	Dry = -50° F to 160° F

*Design meets or exceeds ASME B40.100 pressure gauge standard.*



5

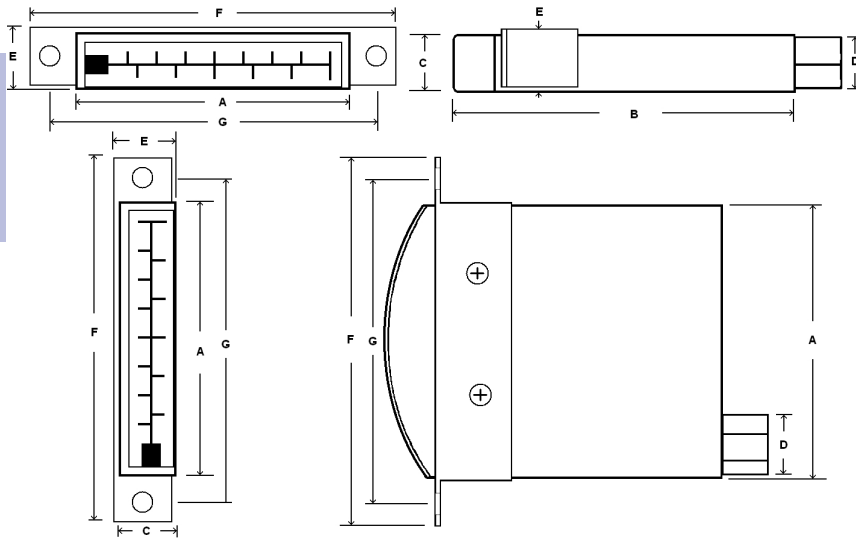

Shown with optional panel mount front bracket

Dial	Unit	A	B	C	D	E	F	G
1 3/4"	In.	1.76"	2.28"	0.51"	0.43"	0.55"	2.5"	2.16"
	mm	45	58	13	11	14	63.6	55

## STANDARD CONFIGURATIONS

Part Number	Range	Connection	Bracket
RECT-60FB	0/60 psi	10/32 back	Front
RECT-60NB	0/60 psi	10/32 back	None
RECT-100FB	0/100 psi	10/32 back	Front
RECT-120FB	0/120 psi	10/32 back	Front

## AVAILABLE OPTIONS\*

- Single Scale psi
- Special Connection Size
- Other Ranges
- Other Mounting Options/Styles
  - Front Bracket
  - Rear Bracket
  - Panel Flange
  - Panel Clip

\*Lead times/minimums may apply

## APPROXIMATE SHIPPING WEIGHTS/ BOX QUANTITIES

Size	Est. Unit Wt.	Box Qty
1 3/4"	0.10 lbs (0.04 kg)	upon request